

LOW-PASS FILTER  
 $R3 \times C1 = 3.3 \text{ mSEC}$   
 $F(3\text{db}) = 48 \text{ Hz}$

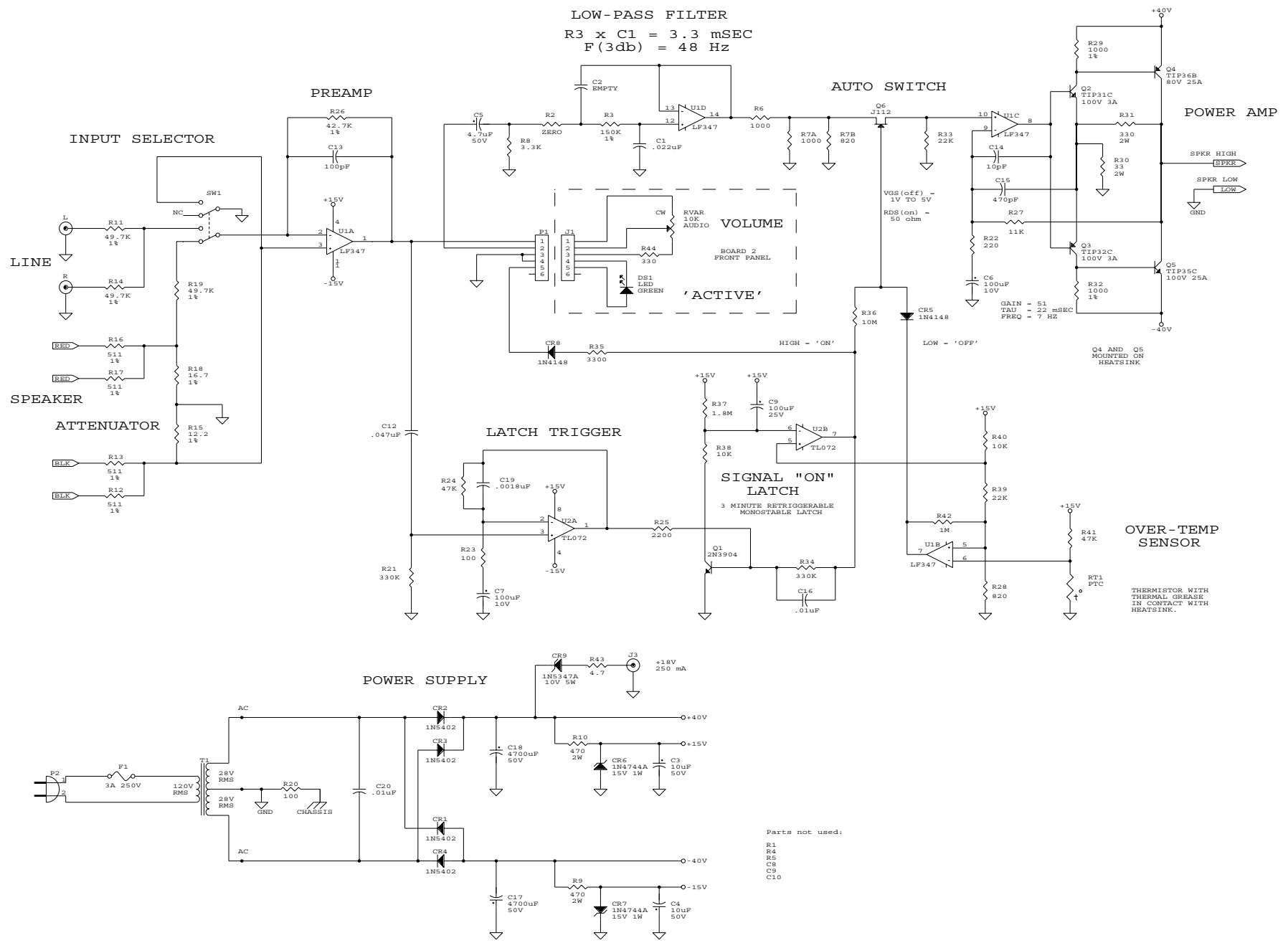

Parts not used:  
 R1  
 R4  
 R5  
 R8  
 C5  
 C6  
 C9  
 C10